



**International Shooting Sport Federation
Internationaler Schiess-Sportverband e.V.
Fédération Internationale de Tir Sportif
Federación Internacional de Tiro Deportivo**

Errata for ISSF Rules and Regulations

(Combined first and second printing)

Edition 2009 (First printing, 11/2008)

Dated: 21.04.2011

ISSF General Regulations

Insert article 3.12.3.1 Annex “Q”

Special Regulations for the participation in the shooting Sport Events of the Olympic Games

Q.1.0 Events

Q.1.1 On the program of the Olympic Games, the Shooting Sport is represented with fifteen different events in three (3) Olympic Disciplines.

Q.1.2 Rifle Discipline

Q.1.2.1 Events for Men

50m Rifle Prone Men	(60 shots prone)
50m Rifle 3 Positions Men	(3 x 40 shots)
10m Air Rifle Men	(60 shots standing)

Q.1.2.2 Events for Women

50m Rifle 3 Positions Women	(3x20 shots)
10m Air Rifle Women	(40 shots)

Q.1.3 Pistol Discipline

Q.1.3.1 Events for Men

50m Pistol Men	(60 shots)
25m Rapid Fire Pistol Men	(60 shots)
10m Air Pistol Men	(60 shots)

Q.1.3.2 Events for Women

25m Pistol Women	(30+30 shots)
10m Air Pistol Women	(40 shots)

Q.1.4 Shotgun Discipline

Q.1.4.1 Events for Men

Trap Men	(125 targets)
Double Trap Men	(150 targets)
Skeet Men	(125 targets)

Q.1.4.2 Events for Women

Trap Women	(75 targets)
Skeet Women	(75 targets)

Q.2.0 Quota

	Qualification	Tripartite Commission places	Host country places	Total
Men	218	24	5	390
Women	139		4	
TOTAL	357	24	9	390

Q.2.1 Quota per NOC

Quota per NOC	
Men	18 (Max 2 per event)
Women Rifle/Pistol events	8 (Max 2 per event)
Women Trap event	1 (Max 1 per event)
Women Skeet event	1 (Max 1 per event)
TOTAL maximum quota per NOC	28

Q.3.0 Athlete Eligibility

Q.3.1 All athletes must comply with the provisions of the Olympic Charter currently in force and only those athletes who have complied with the Olympic Charter may participate in the Olympic Games.

Q.3.2 Minimum Qualification Score (MQS)

Q.3.3 Only athletes who have attained the MQS can be entered in one or more events on the Olympic shooting program. MQS can only be obtained in eliminations and in qualification events at 2010 and 2011 ISSF World Championships, 2011 and 2012 ISSF World Cups, 2010, 2011, 2012 Continental Championships and in ISSF designated Qualification Competitions. The full list of events is published in the ISSF Events Calendar on the ISSF website. The MQS have been established as follows:

Men			
50m Rifle Prone Men	587	10m Air Pistol Men	563
50m Rifle 3 Positions Men	1135	Trap Men	112
10m Air Rifle Men	570	Double Trap Men	118
50m Pistol Men	540	Skeet Men	114
25m Rapid Fire Pistol Men	560		

Women			
50m Rifle 3 Positions Women	555	10m Air Pistol Women	365
10m Air Rifle Women	375	Trap Women	58
25m Pistol Women	555	Skeet Women	60

Q.4.0 Qualification System**Q.4.1 Qualification Pathway**

Q.4.1.1 Quota places can be obtained in ISSF supervised Competitions / Championships according to the ISSF Rules and Regulations. They are:

- ISSF World Championship 2010 & 2011
- ISSF World Cups 2011
- Continental Championships 2010/2011/ 2012

Each shooter who wins or obtains one of the following named places in the qualification events obtains one starting position for his NOC in the Olympic Games.

QUOTA PLACES IN DETAILS for London Olympic Games 2012

Qualification Discipline Event	Total	Men Rifle 50m3x40	Men Rifle 50mProne	Men Rifle AR60	Men Pistol 50mPistol	Men Pistol AP60	Men Pistol RFP	Men Shotgun Trap125	Men Shotgun DT150	Men Shotgun Skeet125	Women Rifle 50m3x20	Women Rifle AR40	Women Pistol AP40	Women Pistol 25mPistol	Women Shotgun Trap75	Women Shotgun Skeet75
2010 ISSF World Championships	69	5	5	6	4	6	2	5	3	5	5	6	6	5	3	3
2011 Separate Shotgun WCH	5							1	1	1					1	1
2011: 1st and 2nd places in all events but first three in air rifle/pistol events	136	8	8	12	8	12	8	8	8	8	8	12	12	8	8	8
Continental Championships 2010/2011/2012																
Europe	48	4	3	4	3	4	2	5	1	5	4	4	4	3	1	1
America	31	2	2	3	2	2	1	3	1	3	3	3	2	2	1	1
Asia	35	3	2	2	2	2	2	4	2	4	3	2	2	3	1	1
Africa	15	1	1	1	1	1	1	1	1	1	1	1	1	1	1	1
Oceania	18	1	2	1	1	1	1	2	1	2	1	1	1	1	1	1
Host Nation	9	1				1	1	1		1		1		1	1	1
	366	25	23	29	21	29	18	30	18	30	25	30	28	24	18	18
	24	Tripartite Commission Invitation Places														
Total	390															

Men	223	Rifle	77	Pistol	68	Shotgun	78
-----	-----	-------	----	--------	----	---------	----

Women	143	Rifle	55	Pistol	52	Shotgun	36
-------	-----	-------	----	--------	----	---------	----

Total	366	plus 24 Tripartite Commission Invitation Places					
-------	-----	---	--	--	--	--	--

Q.4.1.2 Qualification Procedure

Q.4.1.2.1 One quota place is one starting position for the Olympic Games. The quota places are granted to the NOC and not to the athletes who obtained them.

Q.4.1.2.2 The quota place can be achieved by a shooter in the Olympic shooting events at specially designated competitions. A quota place can only be achieved if the result obtained is equal to or higher than the Minimum Qualification Score (MQS) in that event.

Q.4.1.2.3 One shooter can obtain only one quota place for his NOC. If a quota place is achieved by a shooter who has already won a quota place in any event, the quota place will be granted to the next ranked shooter in that competition. The same rule applies when the NOC of a shooter has already obtained the maximum number of quotas per event.

Q.4.1.2.4 Ties for quota places will be broken in accordance with Chapter 12.0 and/or 14.0 of the appropriate discipline rules in the Olympic Shooting Disciplines.

Q.4.1.3 Double Starters at Olympic Games

Q.4.1.3.1 Each shooter, who has been entered in one event in a quota place by his/her NOC, can be entered as a double starter in other events if he/she has also obtained the MQS in the other events and it is possible within the NOC quotas of athletes per event.

Q.4.1.3.2 For Trap and Skeet events for women each NOC is limited to one (1) athlete quota only, but may enter up to two (2) athletes if the second athlete is a double starter.

Q.4.1.3.3 If an NOC enters one (1) athlete as a double starter in any event in which it has also obtained the maximum number of quota place(s), the quota place must be returned to the ISSF/IOC to be granted as an additional quota place.

Q.4.1.4 Qualification Competitions

Q.4.1.4.1 The ISSF Executive Committee will designate the location of those international competitions which will receive the status of ISSF World Cup and qualification events.

Q.4.1.4.2 For all qualification events, the appropriate Discipline Rules will apply.

Q.4.1.4.3 For World Cups or separate MQS competitions the maximum entry per ISSF member federation is three (3) participants per event for the quota places and a maximum of two (2) additional participants for obtaining the Minimum Qualification Scores (MQS).

Q.4.2 Host Country Representation

Q.4.2.1 For the Host Country (NOC) one quota place (starting position) is reserved in the following events:

Men	Women
50m Rifle 3 Positions Men	25m Pistol Women
25m Rapid Fire Pistol Men	10m Air Rifle Women
10m Air Pistol Men	Trap Women
Trap Men	Skeet Women
Skeet Men	

Q.4.2.2 The remaining events may be entered as double starters.

Q.4.3 Tripartite Commission Invitation Places

Q.4.3.1 24 Tripartite Commission Invitation Places are made available for eligible NOCs.

Q.4.3.2 On 1 November 2011, the International Olympic Committee will contact all those NOCs who are eligible to apply for Tripartite Commission Invitation Places.

Q.4.3.3 The deadline for NOCs to submit their requests for Tripartite Commission Invitation Places is 16 January 2012. In relation to the end of the qualification period, the Tripartite Commission will confirm, in writing, the allocation of invitation places to the respective NOCs between 1 May and 9 July 2012.

Q.4.3.4 Detailed information on Tripartite Commission Invitation places is contained in the – Tripartite Commission Invitation Places - Information Paper for NOCs – which is included in the Games of the XXX Olympiad, London 2012 Qualification and Participation Criteria.

Q.5.0 Confirmation process for quota places

Q.5.1 The ISSF will establish a list of the quota places obtained for each event. In this list the maximum number of quota places per NOC will be entered.

Q.5.1.1 This list of quota places and a list with the names and scores of all athletes who have obtained a MQS will be submitted to all NOCs, and all ISSF Member Federations by 27 February, 2012. All NOCs must inform the ISSF by 12 March, 2012 as to how many of their quota places in each event will be used. Each NOC decides the number of entries to fill quota places and selects the athletes in each event from the ones with minimum qualification scores.

Q.5.1.2 On request of an NOC/ISSF Member Federation the maximum of one (1) quota place in one event can be changed for one (1) quota place in any other event if available. The application for a change must be received by the ISSF by 12 March, 2012.

Q.6.0 Reallocation of unused quota places**Q.6.1 Reallocation of unused IF quota places**

Q.6.1.1 Unused IF quota places will be reallocated to the NOC(s) with the largest number of MQS athletes which has not yet qualified for a quota place for the London 2012 Olympic Games.

Q.6.2 Reallocation of unused Host Country quota places

Q.6.2.1 Should the Host NOC not use the Host Country quota place(s) they will be reallocated to the NOC(s) with the largest number of MQS athletes, which has not yet qualified for the London 2012 Olympic Games.

Q.6.3 Reallocation of unused Tripartite Commission quota places

Q.6.3.1 Any unused Tripartite places will be reallocated by the Tripartite Commission. Should the Tripartite Commission not be able to reallocate the quota place(s) they will be reallocated to the NOC(s) with the largest number of MQS athletes, which has not yet qualified for the London 2012 Olympic Games.

Q.7.0 Qualification timeline

Date	Milestone
July 2010 to July 2012	Quota places can be obtained in special quota qualification competitions
29 July – 11 August 2010	50 th ISSF World Shooting Championship (Munich, GER)
18 – 27 November 2010	American Continental Championships (Rio de Janeiro, BRA)
1 – 9 March 2011	ISSF World Cup (Concepcion, CHI)
21 March – 1 April 2011	ISSF World Cup (Sydney, AUS)
7 – 15 April 2011	ISSF World Cup (Changwon, KOR)
19 – 28 April 2011	ISSF World Cup (Beijing, CHN)
14 – 23 May 2011	ISSF World Cup (Fort Benning, USA)
25 May - 4 June 2011	African Continental Championships - Shotgun events (Rabat, MAR)
16 – 23 June 2011	ISSF World Cup (Munich, GER)
7 – 16 July 2011	ISSF World Cup (Gaj-Maribor, SLO)
31 July – 14 August 2011	European Continental Championships (Belgrade, SRB)
3 – 14 September 2011	ISSF World Shotgun Championships (Belgrade, SRB)

Date	Milestone
2011 – Dates TBC	African Continental Championships – 10m, 25m and 50m events (Location TBC)
13 – 24 October 2011	Pan-American Games (Guadalajara, MEX)
1 November 2011	IOC will contact all NOCs who are eligible to apply for Tripartite Commission Invitation Places
27 November – 4 December 2011	Oceania Continental Championships (Sydney, AUS)
11 – 22 January 2012	Asian Continental Championships (Doha, QAT)
16 January 2012	Deadline for NOCs to submit their requests for Tripartite Commission Invitation Places
14 – 20 February 2012	European Continental Championships - 10m events (Vierimaeki, FIN)
27 February 2012	ISSF sends list of quota places obtained to NOCs/ISSF Member Federations
12 March 2012	Deadline for NOCs to confirm use of allocated quota place(s)
March – June 2012	Reallocation of unused quota places
1 May – 9 July 2012	The Tripartite Commission will confirm, in writing, the allocation of Invitation Places to NOCs
9 July 2012	Deadline for London 2012 Organising Committee to receive entry forms

ARTICLE 3.12.3.9 ANNEX “J”



International Shooting Sport Federation
Internationaler Schiess-Sportverband e.V.
Fédération Internationale de Tir Sportif
Federación Internacional de Tiro Deportivo
 ISSF • Bavariaring 21 • D-80336 München • Germany
 Phone: +49-89-5443550 • e-mail: munich@issf-sports.org
 Fax: +49-89-54435544 • internet: http://www.issf-sports.org

Application for Judge's License Renewal

The Federation of	Name of national federation		endorses the application of:	
Family Name(s)		Given Name(s)		
Date of Birth:	Day	Month	Year	
to have the license renewed:				
License Number:		Class:	A	B
Disciplines:				
Rifle <input type="checkbox"/>	Pistol <input type="checkbox"/>	Shotgun <input type="checkbox"/>	Running Target <input type="checkbox"/>	Paper Target Control <input type="checkbox"/>
Electronic Target Control <input type="checkbox"/>				
The ISSF Member Federation confirms that the applicant has obtained experiences as a jury member in international, regional or national level competitions during the last four year period.				
The applicant has good knowledge of the current ISSF Rules and Regulations.				
This is to certify that the information given is correct and the photograph(s) are of the applicant.				
Signed for the Federation:				Please enclose two recent photos by 3 x 2 cm or send a digital photo to the ISSF Headquarters
Name typed or printed:				
Fee enclosed: Euro 15.00 <input type="checkbox"/>				
Two Photographs enclosed <input type="checkbox"/>			Digital Photo sent to ISSF Headquarters <input type="checkbox"/>	

ARTICLE 3.12.3.9.1 ANNEX “S”

- 5.1 Only courses that have been approved and recognized by the ISSF will be considered as official training courses for shotgun referees. Applications for recognition must be submitted to the ISSF Headquarters as soon as possible before the date of the intended course. The application must include:

ISSF Eligibility Rules

- 4.4.2.2 No manufacturer or sponsor identification is permitted on the blinder on the rear sight or on the front or side blinders attached to the hat, cap, shooting glasses or to the head band.

Table 1: Special Rules for Sponsor Markings

Front / Rear Sight Blinders	No sponsor marking	
-----------------------------	--------------------	--

ISSF Anti-Doping Regulations

- 5.1.3.3 The Anti-Doping Committee is responsible for the establishment of the Test Distribution Plan, supervision, and correct execution of the doping tests.

5.5.3.1 Therapeutic Use Exemptions ("TUE")

Shooters with a documented medical condition requiring the use of a Prohibited Substance or a Prohibited Method must be in possession of a Therapeutic Use Exemption ("TUE"). It is recommended that, via ADAMS, Shooters apply for their TUE at the same time as they submit their whereabouts information. The TUE application process and granting or denial process will at all times be governed by the applicable provisions of the International Standard for Therapeutic Use Exemptions. All Shooters participating in ISSF events, whether they are included in the ISSF Registered Testing Pool or not, should apply for their TUE no later than thirty (30) days before the Shooter's participation at an Event. However, when applicable, Shooters may apply for a retroactive TUE in accordance with the applicable provisions of the International Standard for Therapeutic Use Exemptions.

5.6.4.1 International Level Registered Testing Pool

The International Level Registered Testing Pool consists of the top ranked Shooters of the official ISSF World Ranking List which is published on the ISSF Internet website and updated monthly for each International Event. On January 1st of each year, the International Level Registered Testing Pool shall consist of the top 5 Shooters of the official ISSF World Ranking List on that date. Once a Shooter moves into the top 5 ranked athletes of the official ISSF World Ranking List during the current calendar year, he/she shall automatically be included in the International Level Registered Testing Pool for that whole calendar year.

- 5.6.4.3.1 After receipt of two (2) formal written warnings from ISSF or an ISSF Member Federation, any Shooter in the ISSF Registered Testing Pool who fails to submit timely whereabouts report when required to do so, in the preceding eighteen (18) months will be considered to have committed an anti-doping rule violation pursuant to Article 5.3.4.

5.8.1.4

When:

- a) Emergency treatment or treatment of an acute medical condition was necessary; or
- b) Due to exceptional circumstances, there was insufficient time or opportunity for an applicant to submit, or a TUE Committee to consider, an application prior to doping control.

Then, before the Adverse Analytical Finding is referred to the ISSF Anti-Doping Committee, the Shooter shall be given an opportunity to apply to the TUE Committee for a Retroactive TUE in accordance with the International Standard for Therapeutic Use Exemptions. The result of that application shall be forwarded to the ISSF and the ISSF Anti-Doping Committee for consideration in its review of the Adverse Analytical Finding.

Former Articles 5.9 to 5.9.6.2 will be replaced as follows:

5.9 Hearings

5.9.1 Hearings Arising from ISSF Testing or Tests at ISSF Events

5.9.1.1 When it appears following the results management process described in article 5.8 that these Anti-Doping Rules have been violated in connection with ISSF Testing at an ISSF Event, then the case shall be assigned to the anti-doping Commission of Inquiry.

5.9.2 For the purpose of determining the nature, the circumstances and the seriousness of the doping offence, the Commission of Inquiry must provide the Shooter or other Person an opportunity to submit his/her point of view either:

5.9.2.1 orally, or

5.9.2.2 by documentary evidence.

5.9.3 The Shooter or other Person has a right to be heard and to representation at his/her costs.

5.9.3.1 he/she may produce any evidence which may assist his/her defense, including expert testimony and statements; and if appropriate may be accompanied by an interpreter.

5.9.4 Once it is in possession of all the evidence, statements and documents relevant to the case, the Commission of Inquiry must be satisfied that:

5.9.4.1 There were no departures from the International Standard for Testing, International Standard for Therapeutic Use Exemptions or the International Standard for Laboratories which could have caused or resulted in the Anti-Doping Rule Violation, and that

5.9.4.2 The Executive Committee will be sufficiently well informed about all the circumstances of the case in order to be able to render a reasoned decision.

5.9.4.3 In the event that the above criteria is not fulfilled, the Commission of Inquiry will either seek further evidence and expert advice on the case or decide not to bring forward the adverse analytical finding as an anti-doping rule violation.

- 5.9.5 Once the Commission of Inquiry is informed of all the facts of the case to its satisfaction and convinced that there were no procedural irregularities or departures from the Rules,
- 5.9.5.1 if the Shooter or other Person has chosen a documentary hearing, the Commission of Inquiry will transfer the case over to the Executive Committee to allow its members to render a written, reasoned and timely decision in the matter based on the evidence before them.
- 5.9.5.2 if the shooter has elected to proceed by oral hearing, the Commission of Inquiry will transfer the case over to a three person hearing Panel appointed by the Executive Committee and composed of at least one lawyer and one doctor. This hearing Panel will hear the case and render a written and reasoned decision on behalf of, and approved by, the ISSF Executive Committee.
- 5.9.5.3 In all cases, the Executive Committee's decision must be communicated to the Shooter or other Person, the relevant Member Federation and WADA.
- 5.9.6 A Shooter or other Person may forego a hearing by acknowledging the asserted Anti-Doping Rule Violation and accepting the consequences of articles 5.10 and 5.11.
- 5.9.6.1 The right to a hearing may be waived either expressly or by the Shooter or other Person's failure to challenge the ISSF's assertion that an Anti-Doping Rule Violation has occurred within ten (10) days of the receipt of notice thereof.
- 5.9.6.2 In accordance with article 5.9.6, where no hearing occurs, the Commission of Inquiry shall render a written and reasoned decision on behalf of, and approved by, the Executive Committee.
- 5.9.6.3 The written decision must be communicated to the Shooter or other Person, the relevant Member Federation and WADA.
- 5.9.7 In all cases the decisional body responsible for rendering the decision shall be independent and impartial.
- 5.9.7.1 None of the members of the Commission of Inquiry or of the hearing Panel appointed by the Executive Committee may be from the same country as the Shooter or other Person concerned.
- 5.9.7.2 Any member of the Executive Committee who is from the same country as the Shooter or other Person concerned shall disqualify himself or herself from the decision making process.

Former Article 5.9.6: Hearings arising from National Events is renumbered to 5.9.8: Hearings arising from National Events and its content stays the same.

Former Articles 5.9.1.2 and 5.9.1.3 will be deleted.

5.10. AUTOMATIC DISQUALIFICATION OF INDIVIDUAL RESULTS

- 5.10.1 An anti-doping rule violation occurring during or in connection with an Event may lead to Disqualification of all of the Shooter's individual results obtained in that Event with all consequences, including forfeiture of all medals, points and prizes, except as provided in Article 5.10.2

5.10.2. If the Shooter establishes that he/she bears No Fault or Negligence for the violation, the Shooter's individual results in the other Competitions must not be disqualified unless the Shooter's results in Competitions other than the Competition in which the Anti-Doping Rule Violation occurred were likely to have been affected by the Shooter's Anti-Doping Rule Violation.

Delete and replace: old 5.11.1, 5.11.1.1, 5.11.1.2 and 5.11.1.3 with 5.11, 5.11.1 and 5.11.2 only

5.11 SANCTIONS ON INDIVIDUALS

5.11.1 Imposition of Ineligibility for Prohibited Substances and Prohibited Methods.

5.11.2 The period of Ineligibility imposed for a violation of Article 5.3.1 (Presence of Prohibited Substance or its Metabolites or Markers), Article 5.3.2 (Use or Attempted Use of Prohibited Substance or Prohibited Method) and Article 5.3.6 (Possession of Prohibited Substances and Methods) shall be as follows, unless the conditions for eliminating or reducing the period of ineligibility, as provided in Articles 5.11.4 and 5.11.5, or the conditions for increasing the period of ineligibility, as provided in Article 5.11.6, are met:

5.11.2.1 First violation: Two (2) years;

5.11.8.1 During such remaining period of Ineligibility, a minimum of two (2) tests must be conducted on the Shooter with at least three (3) months between each test. The Member Federation shall be responsible for conducting the necessary tests, but tests by any Anti-Doping Organization may be used to satisfy the requirement. The results of such tests must be reported to the ISSF. Once the period of a Shooter's Ineligibility has expired and the Shooter has fulfilled the conditions of reinstatement, then the Athlete will become automatically re-eligible and no application by the Shooter or by the Shooter's Member Federation will then be necessary.

5.21.3 The first ISSF Anti-Doping Rules were approved by the ordinary General Assembly of the UIT (ISSF) on October 30, 1982 in Caracas, Venezuela and were modified by decisions of the Administrative Council on April 22, 1996 in Atlanta, USA, on March 21, 2000 in Sydney, Australia, on April 29, 2001 in Cairo, Egypt, by unanimous postal vote on June 17, 2001 in Munich, Germany, by postal vote on November 7th, 2003 and will be effective from January 1, 2004, by postal vote on January 25, 2007 and by postal vote on December 19, 2009. Some corrections and amendments have been approved by the Administrative Council in the meeting on July 26, 2010 which will be effective immediately.

5.22.8 In case of a conflict between the Code and the ISSF Anti-Doping Rules, the Code shall prevail. Any amendments made by WADA to the Code or its International Standards shall also automatically have authority and be applicable to the ISSF Anti-Doping Rules.

Changes in the Definitions:

Competition:

A single race, match, game or singular athletic contest. For example a basketball game or the finals of the Olympic 100 meter dash in athletics. For the purpose of these anti-doping rules, a Competition is any individual Competition in the course of an ISSF Event. For example 50m Rifle Prone Men, 50m Rifle 3 Positions Men, Skeet Men, 25m Pistol Women and team events are all Competitions within any ISSF World Cup Event.

Nota bene: For the purpose of all Shooting Sport regulatory documents other than these anti-doping rules, the word "Competition" still means a sporting event conducted together under one ruling body. For example the Olympic Games, ISSF World Championships, or Pan American Games, or World Cup, or Continental Championships.

Event:

A series of individual Competitions conducted together under one ruling body. e.g., the Olympic Games, FINA World Championships, Pan American Games, or a Shooting World Cup.

Nota bene: For the purpose of all Shooting Sport regulatory documents other than these anti-doping Rules, the word "Event" still means a completed match with or without Final or Shoot-off as may be further defined in those documents.

Event Period:

The time between the start of the first Competition and the end of the last Competition of an Event, including the Sample collection process related to such Competition.

In-Competition:

Means the period commencing 12 hours before an individual Competition in which the Shooter is scheduled to participate in the course of an Event, through the end of such Competition and the Sample collection process related to such Competition.

Out of Competition:

Any doping control which is not in-competition. Meaning any period of time 12 hours before the commencement of an individual Competition in the course of an Event.

Nota bene: If a World Cup is scheduled from the 1st to 5th of a certain month, and a Shooter in a certain discipline only has a Competition scheduled on the 3rd, even if the Event has started on the 1st, the Shooter can still be tested OOC in the course of the Event Period, so long as the Doping Control takes place 12 hours or more before the start of the Shooter's Competition on the 3rd.

Technical Rules for all Shooting Disciplines

6.1.4 Knowledge of the Rules

All shooters, team leaders and officials must be familiar with the ISSF Rules and must ensure that these Rules are enforced. It is the responsibility of each shooter to comply with the Rules.

Renumber old 6.1.4 to 6.1.4.1 and old 6.1.4.1 to 6.1.4.2 and delete 6.10.2.1

6.1.5.2.1 For Shotgun: Chief of Referee and Referees

When on duty they are required to wear the “ISSF Shotgun Referee (blue) vest” which must be purchased from the ISSF Headquarters (note: as of WCH 2010).

6.3.3 Paper Sighting Targets

Sighting targets must be marked clearly with a black diagonal stripe in the upper right hand corner of the target. The stripe must be clearly visible to the naked eye at the appropriate distance under normal light conditions (except for the 25m Rapid Fire Pistol Target and the 50m Running Target).

6.3.4.1 Backing Targets for 50m and 300m ranges

6.3.4.4 Backing Cards – Electronic Scoring Targets 10m/ 50m/ 300m

A Backing Card must be affixed to the rear of the target which must be renewed and collected for each relay and in 50m and 300m Rifle 3 Positions Men for each position unless a Control Sheet is used. (except at 10m when a black paper strip is used).

6.3.8.4 The firing line must be clearly marked. The range distance must be measured from the target line to the edge of the firing line nearest to the shooter. The use of a board as a firing line is not permitted. The competitor’s foot or, in the prone position the competitor’s elbow may not be placed on or in front of the firing line.

6.3.15.1.1 The nearest edge of the bench or stand must be placed 10 cm forward of the 10m Firing line.

6.3.16.10.3 25m Pistol and 25m Center Fire Pistol Rapid Fire Stage:
facing for three (3) seconds for each shot, alternating with an edge-on face away time of seven (7) seconds (± 0.1 second);

6.3.19.4 The traps must be released by an electric-manual or electric-microphone system. The control system must be placed in such a position that the puller can clearly see and hear the call of the shooter. The release devices must guarantee equal distribution of targets to each shooter in a series of 25 targets. This distribution must be: 10 targets to the right, 10 targets to the left and 5 targets to the center. With the correct distribution, in a series of 25 targets, each group of traps must throw two targets from the left trap, two from the right trap and one from the center trap as the shooters progress from station 1 to 5. After every five (5) targets the selector index must be advanced one (1) step.

6.3.22.3.3 Targets properly released must pass through a circle 0.9 m – 0.95 m in diameter, located 4.60 m \pm 0.05 m above the center point.

6.5.4.9.1 The second 30 shot stage must begin only after all shooters have completed the first 30 shot stage. If there are fewer shooters than are necessary to completely fill all relays then gaps must be left in the last relay of the first stage and in the last relay of the second stage when the event is held over two (2) days.

- 6.6.2.3** The Juries must supervise the examination of the guns, equipment, and accessories (in the Equipment Control Section), and continuously observe the shooting positions and the equipment of the shooters.
- 6.8.15** All irregularities, penalties, misses, malfunctions, extra time allowed, repeated shots / series or annulment of shots, etc., must be clearly marked and recorded on a Range Incident Report Form IR (see form at the end of these Rules), the Range Register, printer strip, on the target and on the score card (paper target) by a Range Officer and/or Jury Member for the attention of the Classification Office.
- 6.10.6.3.1** In the case of a disqualification in the Finals the shooter will be ranked on the last place of the participating finalists, but may retain his Qualification score including any shoot-off before the Finals.
- 6.11.5.2** If a shooter is interrupted for more than five (5) minutes, or moved to another firing point, he may have additional unlimited sighting shots at one sighting target at the beginning of his remaining shooting time together with any time extension granted plus an additional five (5) minutes. If automatic paper target systems which have no possibility for providing a new sighting target are in use, the sighting shots should be fired on the next unused competition target. Two (2) competition shots should be fired at the next competition targets (unless there is only one (1) shot remaining) according to the instructions given by the Range officials or Jury Members. Range officials or Jury Members must ensure that a complete explanation is recorded on the Range Incident Report and if applicable on the Register Keeper's score card.
- 6.13** **FAILURE OF ELECTRONIC SCORING TARGET SYSTEMS – 10m, 50m AND 300m**
- 6.13.3** **Procedure of the failure of a SINGLE target in 10m, 50m and 300m Events**
- 6.13.3.1** If the Electronic Scoring Target cannot be repaired within five (5) minutes, the shooter will be moved to a reserve position and when he is ready to shoot an additional five (5) minutes will be added to the competition time remaining. He will be permitted unlimited sighting shots before he starts the remaining competition shots.
- 6.14.6.2** Shooters with tied scores will have their start positions starting from the left according to the ranking using inner tens.
- 6.14.6.4** In the 10m and 50m Events a Preparation and Sighting period of five (5) minutes will be given followed by five (5) shots (decimal scoring) on command in the relevant Finals shooting position in 75 seconds (prone 45 seconds) per shot. If there is still a tie, it will be decided shot by shot until every tie is broken.
- 6.14.6.5** **Rules for Shoot-offs in all 25m events (full ring scoring)**
- Shooters tied will be allocated new firing points on the Qualification range by drawing of lots by the Jury. If more shooters are tied than target groups are available, the firing sequence will also be determined by drawing of lots.

6.15.4.2.1 If a shooter **contests the value of a shot**, a protest will only be accepted when made before the next shot / series in 25m events (except for failure of the paper or rubber band to advance **or other target failures**) or if it is the last shot, within three (3) minutes.

6.15.4.2.3 If the protest concerning a shot value, other than zero or failure to register, is not upheld, a two (2) point penalty **from the score of the disputed shot** will be awarded and the protest fee must be paid.

Replace chapter 6.16 “Finals in Olympic Events” by the following:

6.16 FINALS IN OLYMPIC RIFLE AND PISTOL EVENTS

6.16.1 General Competition Procedures

6.16.1.1 The full program must be fired in each Olympic Event as a Qualification for the Finals. The eight (8) highest-ranking competitors in the Qualification advance to the Finals except in 25m Rapid Fire Pistol Men, where the six (6) highest-ranking competitors advance. Start positions will be assigned according to the competitors' ranking in the Qualification, starting from the left.

6.16.1.2 The scoring of all Finals, except 25m Rapid Fire Pistol Men, must be conducted with electronic targets or target reading machines or manual devices that classify each ring in ten (10) sections (such as 1.1, 1.2, 1.3, etc., up to the maximum of 10.9). Shots on paper targets that cannot be classified by target reading machines will be scored by hand by Jury Members with ISSF approved instruments.

6.16.1.3 All range commands must be given in the English language.

6.16.2 Reporting to the Range for Finals

6.16.2.1 Team Leaders are responsible for presenting their shooters to the Preparation Area, and report to the Jury at least 30 minutes before the scheduled Start Time, complete with all their shooting equipment needed for the Finals. Finalists must report with their equipment, competition clothing and a national team uniform that may be worn in the awards ceremony. Competitors must be dressed and have only the required shooting equipment. Jury Members and Range Officers must complete their pre-competition checks and trigger weighing in the Preparation Area during this period. Neither gun cases nor equipment containers may be left on the field of play (FOP) behind the firing line.

6.16.2.2 **The Reporting Time** must be printed in the official shooting program. Any delay must be announced and posted on the Finals range.

6.16.2.3 A two (2) point penalty will be deducted from the first Finals shot if the shooter does not report to the Preparation Area in time.

6.16.3 Introduction of Finalists

Any Finalist who is not on his assigned position when the Presentation of Finalists begins is given automatically the last place(s) in the Finals with their Qualification score(s) and is not allowed to participate in the Finals. The Announcer will introduce the Finalists by giving the name, Qualification result and brief information about each Finalist's most important accomplishments. Finalists will be introduced in order starting with the Finalist on the right. The Announcer will also introduce the Chief Range Officer and the Jury Member in charge. After the Preparation and Sighting Period, all Finalists must turn to the rear to face the spectators and stand facing the spectators until all have been introduced. Then they will be allowed to return to the firing points and may handle their guns, dry fire and carry out holding and aiming exercises before and during the Final Preparation time.

6.16.4 10m and 50m Rifle and Pistol Events

6.16.4.1 Firing Times

Event	Men/ Women	Shooting Time
10m Air Rifle / Air Pistol	Men	75 seconds
10m Air Rifle / Air Pistol	Women	75 seconds
50m Rifle 3 Positions (standing position)	Men	75 seconds
50m Rifle 3 Positions (standing position)	Women	75 seconds
50m Rifle Prone	Men	45 seconds
50m Pistol	Men	75 seconds

6.16.4.2 **Finalists in each event:** eight (8) Competitors

6.16.4.3 Starting Positions

The shooters who qualify for the Finals will have their start positions according to the ranking starting from the left.

6.16.4.4 Number of Targets: Ten (10)

6.16.4.4.1 One (1) spare target must be available on the left and right of the eight (8) Finals targets and must show a competition target.

6.16.4.4.2 Monitors displaying the current ranking of the competitors during the Finals must be placed in front of the firing line and be visible to all competitors. In case the monitors fail, there will be no interruption.

6.16.4.4.3 Paper targets only

6.16.4.4.3.1 Number of Sighting Targets: four (4) targets in each event.

6.16.4.4.3.2 Number of Competition Shots per Target: one (1) shot per target.

6.16.4.4.3.3 Number of Record Targets: ten (10) targets in each event.

6.16.4.4.4 Electronic targets only

6.16.4.4.4.1 The target presentation on the spectator monitors must be the same for all monitors and must be easily visible by spectators.

6.16.4.5 Competition rules

6.16.4.5.1 **Start Time** begins with the command **“LOAD”** for the first competition shot for each Finals event. This time must be printed in the official shooting program. Any delay must be announced and posted on the Finals range.

6.16.4.5.2 Each shot fired before the command **“START”** or after the command **“STOP”** will be counted as a miss (zero).

6.16.4.5.3 If a shooter fires more than one (1) shot after each command the score for this Finals shot will be scored as zero.

6.16.4.5.4 If carrier operated target systems are used, the targets must only be brought back to the firing line after the commands **“STOP”** and **“CHANGE TARGETS”**, to avoid disturbing other shooters.

6.16.4.5.5 Aiming exercises are allowed.

6.16.4.5.6 Dry Firing after the Final Preparation and Sighting Period is prohibited and will be penalized by deduction of two (2) points for each case from the first Finals shot.

6.16.5 Finals Procedures for 10m and 50m Events

FINALS	Each Finals consists of ten (10) shots and is conducted single shot for shot using the following commands and procedures.
FINALISTS REPORT 30:00 min. before	Finalists must report to the Finals Preparation Area at least 30 minutes before the Finals Start Time in accordance with Rule 6.16.2.
EQUIPMENT SET-UP 20:00 min. before	The Chief Range Officer must authorize the Finalists to occupy their assigned firing points, move their equipment to their assigned firing points and handle their guns 20 minutes before the Finals Start Time by commanding “SHOOTERS TO THE FIRING LINE” . Gun cases and equipment bags or boxes may not be left behind the firing line on the Finals range field of play (FOP). Aiming exercises may be done during the Equipment Set-Up time. Dry Firing or loading is not permitted until the Preparation and Sighting Time starts.
PREPARATION AND SIGHTING TIME (Warm-up period) 14:30 minutes before	The Chief Range Officer will authorize the Finalists to begin their preparation for the Finals with the command “EIGHT MINUTES PREPARATION AND SIGHTING TIME... START” . Finalists will have eight (8) minutes to complete their preparations, check their firing positions and fire unlimited sighting shots. The Chief Range Officer will command “30 SECONDS” when there are 30 seconds remaining in the warm-up period. The Chief Range Officer will command “STOP, UNLOAD” when the warm-up period ends.

<p style="text-align: center;">END OF PREPARATION 6:30 minutes before</p>	<p>After the “STOP, UNLOAD” command, Finalists must place their guns on the bench or floor. A Range Officer must verify that the actions are open and there are no cartridges in the chambers or magazines. All Finalists must then turn to the rear to face the spectators. <i>Note: Television productions of the Finals will normally be timed to begin at this point.</i></p>	
<p style="text-align: center;">PRESENTATION OF FINALISTS 5:30 minutes before</p>	<p>The Announcer will introduce the Finalists by giving the name, Qualification result and brief information about each Finalist’s most important accomplishments. The Announcer will also introduce the Chief Range Officer and the Jury Member in charge.</p>	
<p style="text-align: center;">FINAL PREPARATION 2:30 minutes before</p>	<p>After the presentation, the Chief Range Officer will command “TAKE YOUR POSITIONS.....TWO MINUTES FINAL PREPARATION AND SIGHTING TIME...START”. The Finalists will have two (2) minutes to resume their positions, prepare and fire sighting or warming shots. The Chief Range Officer will command “30 SECONDS” after 90 seconds have passed and will command “STOP” after the two (2) minutes.</p>	
<p style="text-align: center;">TARGET RESET 0:30 seconds before</p>	<p>There must be a pause of 30 seconds while a Technical Officer resets the targets.</p>	
<p style="text-align: center;">FINALS START 0:00 before</p>	<p style="text-align: center;">“FOR THE FIRST / NEXT COMPETITION SHOT – LOAD”</p>	<p>After this command the shooter loads his gun. The cartridge or pellet must be loaded into the chamber only after the command “LOAD”.</p>
	<p style="text-align: center;">“ATTENTION 3-2-1-START”</p>	<p>The shooter has 75 seconds in which to fire a shot (45 seconds in prone position). This command with the count-down should give the shooters sufficient time to take up their shooting positions. The shooting time starts when the command “START” has been given.</p>
<p style="text-align: center;">SCORE ANNOUNCEMENTS After each shot</p>	<p>After 75 seconds (45 seconds for prone) or after all Finalists have fired one (1) shot, the Chief Range Officer commands “STOP”. This command is given about five (5) seconds after the last shooter has fired, or immediately on termination of the shooting time. The last second must correspond with the word “STOP”. Immediately after the command “STOP”, the Announcer announces the name (family name) and score of each Finalist and then makes 15/20 seconds of comments regarding the leader, the best shots, changes in position, etc.</p>	

(Continued)	Immediately after the score announcement, the Chief Range Officer will give the commands for the next Finals shot.
This sequence is repeated until all ten (10) Finals shots are complete.	
FINALS COMPLETION	After the tenth shot, the Chief Range Officer commands “STOP, UNLOAD” . Individual shot scores will not be announced after the tenth Finals shot. If there are no ties and no protests, the Chief Range Officer must immediately declare “THERE ARE NO TIES. RESULTS ARE FINAL” . Finalists may then move from their firing points.
PROCLAMATION OF MEDALISTS	After the Chief Range Officer declares “RESULTS ARE FINAL” , the Announcer must immediately announce: “THE GOLD MEDAL WINNER IS (NAME) FROM (NATION) WITH A TOTAL SCORE OF (SCORE)” “THE SILVER MEDAL WINNER IS (NAME) FROM (NATION) WITH A TOTAL SCORE OF (SCORE)” “THE BRONZE MEDAL WINNER IS (NAME) FROM (NATION) WITH A TOTAL SCORE OF (SCORE)”
MALFUNCTIONS	In case of an ALLOWABLE MALFUNCTION, the shooter is allowed to repeat the unfired shot once during the Finals, including any Shoot-off, if he can repair or replace his gun or ammunition within three (3) minutes after the malfunction has been declared allowable. In case of a NON-ALLOWABLE MALFUNCTION, no re-shoot is allowed. If a shot has not been fired due to a malfunction, a shooter may try to correct the malfunction in the shooting time remaining. After attempting any correction he may not claim an ALLOWABLE MALFUNCTION, unless a part of the gun is damaged sufficiently to prevent it from firing.
TIE-BREAKING	Tied scores after the Finals for first, second or third place will be broken by a Shoot-off. Ties below third place will be decided by the higher Finals score, or if the tie is not broken, by the Qualification ranking. When shooters are tied for first and third places, the tie for third place will be decided first. If there are ties, the Chief Range Officer must proceed immediately with the tie-breaking shots by commanding “COMPETITORS IN POSITIONS # AND #, STAY ON THE FIRING LINE – OTHER SHOOTERS LEAVE THE FIRING LINE” . The shoot-off competitors must stay on the firing line and all other shooters must immediately leave their guns on the firing line and step back from their firing points.

(Continued)	<p>“COMPETITORS IN POSITIONS # AND #, FOR YOUR SHOOT-OFF SHOT, LOAD...ATTENTION, 3-2-1, START”. Tie-breaking shots will continue one (1) shot at a time until the ties are broken.</p> <p>For multiple 50 meter ties only: If there is a delay of more than five (5) minutes, the Chief Range Officer will, on request, command “WARMING SHOTS...START”. Competitors will have 30 seconds to fire up to three (3) warming shots. The Chief Range Officer will command “STOP” after 30 seconds.</p> <p>After all ties are broken, the Chief Range Officer declares “RESULTS ARE FINAL”.</p>
--------------------	--

6.16.6 Finals Procedures for 25m Pistol Women

FINALS	The 25m Pistol Women Finals competition consists of four (4) 5-shot series fired in the rapid-fire format (3-second exposures).																																	
QUALIFICATION	The full 60-shot program (Rule 8.6.4.4) will be fired as a Qualification for the Finals. The eight (8) highest-ranking competitors in the Qualification advance to the Finals. Start positions will be assigned according to the competitors' ranking in the Qualification, starting from the left (1 st place shooter on position 1, 2 nd place shooter on position 2, etc.). Scores fired in the Qualification carry forward to the Finals and are included in the final result.																																	
TARGETS	<p>Two (2) 5-target groups will be used with Finalists assigned to position according to the chart. The Control sheets / cards and backing targets are not to be changed or patched between series.</p> <table border="1" style="margin-left: auto; margin-right: auto;"> <tr> <td style="text-align: center;">Bay</td> <td colspan="5" style="text-align: center;">A</td> <td colspan="5" style="text-align: center;">B</td> </tr> <tr> <td style="text-align: center;">Target</td> <td style="text-align: center;">1</td> <td style="text-align: center;">2</td> <td style="text-align: center;">(3)</td> <td style="text-align: center;">4</td> <td style="text-align: center;">5</td> <td style="text-align: center;">1</td> <td style="text-align: center;">2</td> <td style="text-align: center;">(3)</td> <td style="text-align: center;">4</td> <td style="text-align: center;">5</td> </tr> <tr> <td style="text-align: center;">Start position</td> <td style="text-align: center;">1st</td> <td style="text-align: center;">2nd</td> <td style="text-align: center;">-</td> <td style="text-align: center;">3rd</td> <td style="text-align: center;">4th</td> <td style="text-align: center;">5th</td> <td style="text-align: center;">6th</td> <td style="text-align: center;">-</td> <td style="text-align: center;">7th</td> <td style="text-align: center;">8th</td> </tr> </table>	Bay	A					B					Target	1	2	(3)	4	5	1	2	(3)	4	5	Start position	1st	2nd	-	3rd	4th	5th	6th	-	7th	8th
Bay	A					B																												
Target	1	2	(3)	4	5	1	2	(3)	4	5																								
Start position	1st	2nd	-	3rd	4th	5th	6th	-	7th	8th																								
REPORTING AND START TIMES 30:00 min. before	The Start Time for the Finals is when the command “LOAD” is given for the first competition series. Competitors must report to the Preparation Area for the competition at least 30 minutes before the Start Time in accordance with Rule 6.16.2.																																	

<p style="text-align: center;">EQUIPMENT SET-UP</p> <p style="text-align: center;">15:00 min. before</p>	<p>The Chief Range Officer will authorize the Finalists to occupy their assigned firing points, move their equipment to their assigned firing points and handle their guns 15 minutes before the Final round start time by announcing “SHOOTERS TO THE FIRING LINE”. Gun cases and equipment bags or boxes may not be left behind the firing line on the Finals range field of play (FOP). Aiming exercises may be done during the Equipment Set-Up time. Dry Firing or loading is not permitted until Preparation begins.</p>
<p style="text-align: center;">PREPARATION PERIOD AND SIGHTING SHOTS</p> <p style="text-align: center;">10:00 min. before</p>	<p>Five (5) minutes after calling the Finalists to the firing line, the Chief Range Officer will begin the 2-minute preparation period by commanding “PREPARATION BEGINS NOW”.</p> <p>After two (2) minutes, the Chief Range Officer will command “END OF PREPARATION”.</p> <p>The sighting series must begin immediately after the preparation period. The sighting series consists of one (1) series fired in the Rapid-Fire sequence. All Finalists will fire the sighting series (and the match series) at the same time and on the same commands. The Chief Range Officer must use the commands listed below (see FINALS START) to conduct the sighting series. No score announcements will be made during the sighting series. After the sighting series, the competitors must place their unloaded pistols on the bench and turn to face the spectators for the presentation of competitors. A Range Officer must verify that the actions are open and there are no cartridges in the chambers or magazines.</p>
<p style="text-align: center;">PRESENTATION OF FINALISTS</p> <p style="text-align: center;">6:00 min. before</p>	<p>After the sighting series, the Announcer will introduce the Finalists by giving the name, Qualification result and brief information about each Finalist’s most important accomplishments. The Announcer will also introduce the Chief Range Officer and the Jury Member in charge. Any Finalist who is not on her assigned position when the Presentation of the Finalists begins is automatically given the last place(s) in the Finals with the Qualification Score(s) and is not allowed to participate in the Finals. After the presentation, the Chief Range Officer will command “TAKE YOUR POSITIONS..... TWO MINUTES FINAL PREPARATION TIME BEGINS NOW”.</p>

FINALS START 0:00 before	The following commands and timing will be used:	
	“FOR THE SIGHTING SERIES...LOAD”	All shooters load within a time of one (1) minute.
	“FOR THE FIRST/NEXT COMPETITION SERIES...LOAD”	All shooters load within a time of one (1) minute.
	“ATTENTION”	The red lights must be switched on, or if paper targets are used, they must be turned to the edge-on position. After a delay of seven (7) seconds (+/- 0.1 second) either the green lights will come on, or the target will be turned to face the shooter.
SCORE ANNOUNCEMENTS After each 5-shot series	Immediately after each competition series, the Announcer reports the name (family name) and score of each Finalist and then makes approximately 15-20 seconds of comments regarding the leader, the best shots, changes in position, etc. Immediately after the comments about the ranking, the next series starts.	
This sequence is completed until all four (4) 5-shot series are complete.		
FINALS COMPLETION	After all Finalists have fired the four (4) competition series, and if there are no ties and no protests, the Chief Range Officer must immediately declare “THERE ARE NO TIES. RESULTS ARE FINAL” . The Finalists are ranked according to the total of their Qualification and Finals scores.	
PROCLAMATION OF MEDALISTS	After the Chief Range Officer declares “RESULTS ARE FINAL” , the Announcer must immediately announce: “THE GOLD MEDAL WINNER IS (NAME) FROM (NATION) WITH A TOTAL SCORE OF (SCORE)” “THE SILVER MEDAL WINNER IS (NAME) FROM (NATION) WITH A TOTAL SCORE OF (SCORE)” “THE BRONZE MEDAL WINNER IS (NAME) FROM (NATION) WITH A TOTAL SCORE OF (SCORE)”	
MALFUNCTIONS	Only one (1) malfunction may be claimed during the Finals. If a malfunction is claimed, a Range Officer must determine if the malfunction is allowable or non-allowable. If the malfunction is allowable, the competitor must fire a series completion in accordance with Rule 8.7. If repairs are required they must be completed within three (3) minutes.	

TIE-BREAKING	<p>Tied scores after the Finals for first, second or third place will be broken by a Shoot-off. Ties below third place will be decided by the higher Finals score, or if the tie is not broken, by their Qualification rankings.</p> <p>Tied shooters will fire one (1) series of five (5) shots in the same times and conditions as in the Finals until the tie is broken.</p> <p>All other competitors must step back from the firing line immediately after the tied competitors have been identified.</p> <p>The tie-breaking Shoot-off will commence without delay.</p> <p>When shooters are tied for first and third places, the tie for third place will be decided first.</p>
---------------------	--

6.16.7 Finals Procedures for 25m Rapid Fire Pistol Men

FINALS	The 25m Rapid Fire Pistol Men Finals consists of four (4) to eight (8) 5-shot 4-second series with hit or miss scoring and the elimination of the lowest scoring Finalists beginning with the fourth series.
QUALIFICATION	The full 60-shot program (Rule 8.6.4.3) will be fired as a Qualification for the Finals. The six (6) highest-ranking competitors in the Qualification advance to the Finals. Start positions will be assigned according to the competitors' ranking in the Qualification, starting from the left. Finalists will start from a score of zero (0).
TARGETS	Three (3) groups of five (5) 25m electronic-scoring targets must be used. Two (2) firing points 1.5 meters apart will be designated for each 5-target group. Each competitor must take his position so that at least one (1) foot touches the line that marks the left or right side of the shooting station as defined by Rule 6.3.16.6 (each line is 75 cm from the center line of the target group).
SCORING	Scoring is hit or miss only; each hit counts one (1) point; each miss counts zero points. The size of the hit zone is within the 9.7 zone on the 25m Rapid Fire Pistol target. The actual size of the hit zone to be used in ISSF Championship Finals may be adjusted by the ISSF Executive Committee, but any changes in hit zone size must be announced in advance. A graphic display of hits and misses in each competition series will be shown on shooter's monitors and on display screens in the Finals range.

<p>(Continued)</p>	<p>Competitors in Finals start from a score of zero (0). Results in the Qualification entitle competitors to participate in the Finals. During Finals, results are cumulative with each shooter's final ranking determined by the total number of hits for all series fired in the Finals (excluding any shoot-offs).</p> <p>If a deduction is applied to the score for a competition series, no score below zero (0) will be recorded (e.g. 3-1 point deduction = 2, 0-1 point deduction = 0).</p>
<p>REPORTING AND START TIME 30:00 min. before</p>	<p>The Start Time for the competition is when the command "LOAD" is given for the first competition series. Competitors must report to the Preparation Area for the competition at least 30 minutes before the Start Time. A one (1) hit penalty will be deducted from the score of the first competition series if the shooter does not report in time (30 minutes before Start Time) for the Finals.</p> <p>Competitors must report with their equipment, competition clothing and a national team uniform that may be worn in the awards ceremony. The Jury must use the Finals Start List to confirm that all Finalists are present and that their names and nations are correctly recorded in the results system and on the scoreboards. Competitors may change clothes if necessary and Juries must complete equipment checks during the reporting period. Competitors must be allowed to place their equipment, which may include a reserve pistol that can be used to replace a malfunctioning pistol, on their firing points not less than 15 minutes before the start time. Neither gun cases nor equipment containers may be left on the field of play (FOP) behind the firing line.</p>
<p>PREPARATION PERIOD AND SIGHTING SHOTS 10:00 min. before</p>	<p>There will be a preparation period and one (1) sighting series before the presentation. The Chief Range Officer will call the competitors to the firing line ten (10) minutes before the start time. The Chief Range Officer will then start a 2-minute preparation period by commanding "PREPARATION BEGINS NOW".</p> <p>After two (2) minutes, the Chief Range Officer will command "END OF PREPARATION".</p>

<p style="text-align: center;">(Continued)</p>	<p>Sighting series must begin immediately after the preparation period. Sighting series will be fired by using the same command and timing sequence described in the Detailed Procedure for Commands and Firing below. Each competitor will fire one (1) sighting series of five (5) shots in four (4) seconds, in sequence, starting with the competitor on the left. No score announcements will be made. After all competitors have completed the sighting series, the competitors must place their unloaded pistols on the bench and turn to face the spectators for the presentation of competitors. A Range Officer must verify that the actions are open and there are no cartridges in the chambers or magazines.</p>
<p style="text-align: center;">PRESENTATION OF FINALISTS 6:00 min. before</p>	<p>After the sighting series, The Announcer will introduce the Finalists by giving the name, Qualification result and brief information about each Finalist's most important accomplishments. The Announcer will also introduce the Chief Range Officer and the Jury Member in charge.</p> <p>Any Finalist who is not on his assigned position when the Presentation of the Finalists begins is automatically given the last place(s) in the Finals with the Qualification Score(s) and is not allowed to participate in the Finals.</p>
<p style="text-align: center;">DETAILED PROCEDURE FOR COMMANDS AND FIRING</p>	<p>Each Finals competition series consists of five (5) shots in four (4) seconds. For each series, all competitors remaining in the competition will shoot separately and in succession. The order of firing for all series is from left to right.</p> <p>Immediately after the introductions the Chief Range Officer will command "SHOOTERS TO THE FIRING LINE".</p> <p>30 seconds after the presentation of competitors, the Chief Range Officer will command "FOR THE FIRST COMPETITION SERIES, LOAD". After the command "LOAD" competitors have one (1) minute to load two (2) magazines (rule 8.6.4.2.3 does not apply for the Finals).</p> <p>Only one (1) "LOAD" command is given before the start of the first competition series. During the entire Finals, competitors may continue to load magazines as required. After the command "LOAD", competitors may do aiming exercises, arm lifts or dry firing except when the other competitor in the 5-target group is firing. During this time the competitor on the right in the 5-target group may take his pistol in his hand to prepare, but he may not do aiming exercises, arm lifts or dry firing. After the competitor on the left has fired his series, he must place his pistol down and step to rear of the shooting station or not move while the competitor on the right fires his series.</p>

<p style="text-align: center;">(Continued)</p>	<p>One (1) minute after the command “LOAD”, the Chief Range Officer will call the name of the first competitor by stating “(FAMILY NAME OF SHOOTER #1)”. After the competitor’s name is announced, he may put the magazine in his pistol and prepare to fire.</p> <p>15 seconds after calling the name of the first competitor, the Chief Range Officer will command “ATTENTION” and turn the red lights on. The first competitor must bring his pistol to the Ready Position (Rule 8.6.1). The green lights will come on after a delay of seven (7) seconds. After the 4-second firing period, the red lights will come on for 10-14 seconds (recycling time of the targets). During this 10-14 second period, the Chief Range Officer will report the score for that series (e.g., “FOUR HITS”).</p> <p>Immediately after the first competitor’s score is announced and the EST Technical Officer signals that the targets are ready, the red lights will go off. As soon as the red lights go off, the Chief Range Officer will announce “(FAMILY NAME OF SHOOTER #2)”. 15 seconds later, the command “ATTENTION” will be given and the timing procedure for that series will proceed. After that series, the Chief Range Officer will report the score.</p> <p>The other competitors will continue to fire in order until all competitors remaining in the competition have fired that series.</p> <p>There will be a 30-second pause after all shooters complete one (1) series. During this pause, the Announcer will comment on the current ranking of the competitors, the best scores, competitors who were eliminated, etc.</p> <p>For the second series, the Chief Range Officer will announce “(FAMILY NAME OF SHOOTER #1)” and continue.</p>
<p style="text-align: center;">START OF FINAL ROUND COMPETITION 0:00 min. before</p>	<p>30 seconds after the presentation of Finalists is complete, the Chief Range Officer will give the commands to begin the firing procedure for the first competitor. This sequence will continue until all competitors remaining in the competition have fired that series. All competitors remaining in the competition will be commanded to fire additional series as required for that stage of the competition. (Details under Detailed Commands and Firing Procedure).</p>

<p>ELIMINATIONS</p>	<p>After all Finalists have fired the fourth series, the lowest ranking shooter is eliminated (6th place).</p> <p>After the remaining Finalists have fired the fifth series, the lowest ranked competitor is eliminated (5th place). After the remaining Finalists have fired the sixth series, the lowest ranked competitor remaining is eliminated (4th place). After the remaining Finalists have fired the seventh series, the lowest ranked competitor remaining is eliminated (3rd place, bronze medal winner).</p> <p>When a competitor is eliminated, he must unload his pistol (remove magazine and open action) and lay it on the bench before stepping back. Any preloaded magazines must be unloaded. A Range Officer must verify that the action is open and that there is no cartridge in the chamber or magazines.</p>
<p>FINALS COMPLETION</p>	<p>After the two (2) remaining Finalists fire the eighth series, and if there are no ties and no protests, the Chief Range Officer will declare “THERE ARE NOT TIES. RESULTS ARE FINAL”. The higher ranking competitor becomes the gold medal winner and the second ranking shooter becomes the silver medal winner.</p>
<p>PROCLAMATION OF MEDALISTS</p>	<p>After the Chief Range Officer declares “RESULTS ARE FINAL”, the Announcer must immediately announce:</p> <p>“THE GOLD MEDAL WINNER IS (NAME) FROM (NATION) WITH A TOTAL SCORE OF (SCORE)”</p> <p>“THE SILVER MEDAL WINNER IS (NAME) FROM (NATION) WITH A TOTAL SCORE OF (SCORE)”</p> <p>“THE BRONZE MEDAL WINNER IS (NAME) FROM (NATION) WITH A TOTAL SCORE OF (SCORE)”</p>
<p>LATE SHOTS (6.16.7.1)</p>	<p>If a competitor fires a late shot or does not shoot at all five (5) targets in time, a deduction of one (1) hit for each overtime, or unfired shot will be taken from the score for that series. The shot will be marked with “OT”.</p>
<p>READY POSITION (6.16.7.2)</p>	<p>If a shooter raises his arm too soon, or does not lower it sufficiently, the shooter must be penalized by a deduction of two (2) hits of the shot series (green card). In case of repetition, the shooter will be disqualified (red card).</p>
<p>MALFUNCTIONS (6.16.7.3)</p>	<p>If a malfunction occurs, a Range Officer must determine if the malfunction is allowable or non-allowable. If the malfunction is allowable, the competitor must re-fire the series and will receive the score of the re-fired series. The competitor has 15 seconds to be ready for the re-fire series. For any further malfunction no re-fire is permitted and the hits that are displayed will be counted.</p> <p>If the malfunction is non-allowable, a penalty of two (2) hits must be deducted from that competitors’ total score.</p>

TIE-BREAKING	<p>If there is a tie for the lowest ranking competitor(s) to be eliminated, the tied competitors will fire additional tie-breaking 4-second series until the tie is broken. For all tie-breaking series, the shooter on the left starts.</p> <p>For the tie-breaking series, the Chief Range Officer will call the name of the first tied competitor by stating “(FAMILY NAME OF SHOOTER #1)” and the normal firing procedure applies.</p>
---------------------	---

6.16.8 Target Failure 10m, 25m, 50m Events

6.16.8.1 If a **failure of all Finals targets** occurs, the following procedure must be used.

6.16.8.2 The shots/series that were completed by all shooters will be scored as a **sub-total**.

6.16.8.3 If the **failure cannot be corrected** to permit continuation of the Finals within one (1) hour, the recorded scores completed (by all shooters not eliminated) will be scored as the Finals Total of the competition and awards made on that basis.

6.16.8.4 **When the failure is rectified** and if it is possible to continue the Finals within one (1) hour, the following procedure will apply:

6.16.8.4.1 10m and 50m Events

The remaining shots will be completed. Five (5) minutes unlimited sighting shots will be permitted after the shooters are in their positions.

6.16.8.4.2 25m Events

The remaining shots/series will be completed. One (1) sighting series will be allowed in the 25m Pistol events.

6.16.8.5 If a single target fails to function:

6.16.8.5.1 10m and 50m Events

The shooter will be moved to a reserved target. On the shooters request he will be permitted an additional two (2) minutes for sighting shots before he repeats the unrecorded previous competition shot(s).

6.16.8.5.2 25m Events

6.16.8.5.2.1 The shooter in the **25m Pistol Women Event** will be moved or the target will be replaced. On the shooter’s request an additional sighting series is permitted before she completes the missed previous competition shot(s).

6.16.8.5.2.2 If one (1) or more targets of a group of five (5) targets fail to function, in the **25m Rapid Fire Pistol Men Event**, the target(s) will be replaced, and the series where the failure occurred will be re-fired. On request, one (1) sighting series will be allowed for all shooters in the competition before the series is re-fired.

6.16.8.6 Final Official Results

6.16.8.6.1 In all events, except 25m Rapid Fire Pistol Men, the results of the Finals competition will be added to the individual results of the Qualification.

6.16.8.6.2 In the **25m Rapid Fire Pistol Men Event** the Results of the Qualification will be shown as well as the number of hits in the Finals (excluding any hits recorded during shoot-offs), but Qualification Scores will not be added to the Finals hit scores.

6.16.8.6.3 For all events, except 25m Rapid Fire Pistol Men, the results of the Qualification and the Finals combined must be shown on the Main Scoreboard and printed in the official results bulletin.

6.16.8.6.4 For the **25m Rapid Fire Pistol Men Event**, the results (as in 6.16.8.6.2) must be shown on the Main Scoreboard and printed in the official results bulletin.

6.16.9 Protests in Finals

6.16.9.1 Any protests must be immediate and made by the shooter or his coach by holding up his hand.

6.16.9.2 Any protest will be decided by the Range Jury immediately.

The decision of the Jury is final, and the protest fee may become payable if the protest is denied.

Page 279 – 25m Rapid Fire Pistol Men Malfunction Score Computation Form “A” please exchange the following:

For ALLOWABLE malfunction insert “AM”, for NON-ALLOWABLE insert “NAM 0”, for UNFIRED SHOTS insert “0” – **only for misses, or for shots not fired on each single target in both series:**

Page 282 – 25m Standard Pistol Men Malfunction Score Computation Form “D” please exchange the following:

For ALLOWABLE malfunction insert “AM”, for NON-ALLOWABLE insert “NAM 0”, for UNFIRED SHOTS insert “0” – **only for misses, or for shots not fired (by shot number) on the target in both series:**

6.20 Index

25m Events – Scoring Procedures – supervision of the Jury	6.9.1.2
Aiming area – only one (1) aiming area	6.3.1.5
Bib (Start) Numbers	6.4.10
Cross-fires – Sighting shot on a competition target of another shooter	6.11.8.1.1
Cross-fires – Sighting shot on a sighting target of another shooter	6.11.8.2
Dimensions of scoring rings (outside diameter)	6.3.1.4
Electronic Scoring Targets (EST)	6.3.1.7
Finals – Failure of all Finals targets	6.16.6.5.1
Finals – Protests in Finals	6.16.7
Finals – Protests in Finals – Decisions	6.16.7.2
Horizontal variations for Firing Points	6.3.11
Horizontal variations for Target Centers	6.3.10
Indoor range – light measuring	6.3.17.4
Indoor range – light requirements (Lux)	6.3.17

Inner Tens Marking - Air Rifle: inner ten outward scoring gauge	6.3.2.8.4.1
Inner Tens Marking - Air Pistol: inner ten outward scoring gauge	6.3.2.8.4.2
Knowledge of the Rules	6.1.4
Left-handed	6.1.4.1
Light measuring on indoor ranges	6.3.17.4
Main scoreboard	6.8.1.1
Men's event	6.1.4.2
Paper targets – Handling of targets	6.11.1
Right-handed	6.1.4.1
Scoring zones – scoring rings	6.3.1.6
Shot(s) before the command START	6.11.2.2.2
Women's event	6.1.4.2
World Records: setting – equalling – breaking	6.17.1

Rifle Rules

7.4.3.2

Text remains the same but replace old drawing with drawing below

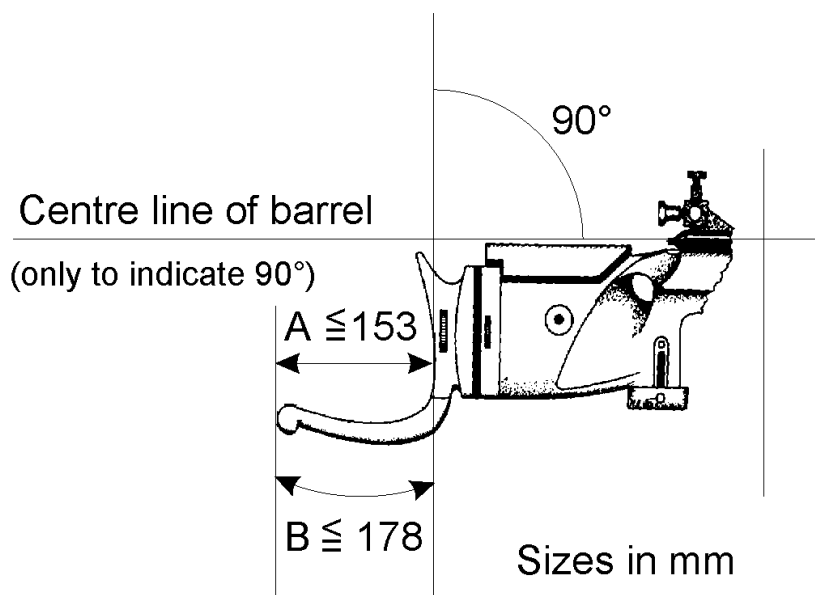

7.4.7.6

No Velcro, sticky substance, liquid, or spray may be applied to the outside or inside of the jacket, pads or shoes and/or floor or equipment. Roughening the material of the jacket is permitted. Violations will be penalized according to the Rules.

7.4.7.8.1 The trousers, including the lining, must not exceed 2.5 mm in single thickness and 5 mm in double thickness at any point where flat surfaces may be measured. The top of the trousers must not fit or be worn higher on the body than 50 mm above the crest of the hipbone. All drawstrings, zippers or fasteners to tighten the trousers around the legs or hips are prohibited. To support the trousers only a normal waist belt not more than 40 mm wide and 3 mm thick or braces (suspenders) may be worn. If a belt is worn in the standing position, the buckle or fastening must not be used to support the left arm or elbow. The belt must not be doubled, tripled etc. under the left arm or elbow. If the trousers have a waist band, it may not be more than 70 mm wide. If the thickness of the waistband exceeds 2.5 mm, a waist belt is not permitted. If a waist belt is not worn, the absolute maximum thickness of the waistband is 3.5 mm. Each belt loop (keeper) must not exceed 20 mm width. The trousers may be closed by one hook and up to five (5) eyes, or up to five (5) adjustable snap fasteners, or similar closure or Velcro which must not be multilayered. Only one type of closure is permitted. A Velcro closure combined with any other closure is prohibited. The trousers must be loose around the legs. If special shooting trousers are not worn, ordinary trousers may be worn providing they do not give artificial support to any part of the body.

7.5.1.2.1 The shooter must stand free with both feet on the firing point surface or on the shooting mat without any other support.

7.5.1.2.10 The right hand may not touch the left hand, left arm or the left sleeve of the shooting jacket.

7.5.1.3.14 The right hand may not touch the left hand, left arm or the left sleeve of the shooting jacket or sling.

7.10 Index

Clothing under the jacket and trousers	7.4.7.10.1
Manipulation of material before or during the follow-up controls	7.4.6.4.2.6
Reinforcements	7.4.7.8.2.3
Reinforcements – Table	7.4.6.4.1.1
Rifle Events – See the Rifle Event Table 7.8	7.8
Slings	7.4.1.4.5
Thickness – Table	7.4.6.4.1.1
Underwear	7.4.7.10.2
Undergarment	7.4.7.10.1

Pistol Rules

8.4.1.6

Measuring the Weight of the Trigger Pull

Metal knife-edge

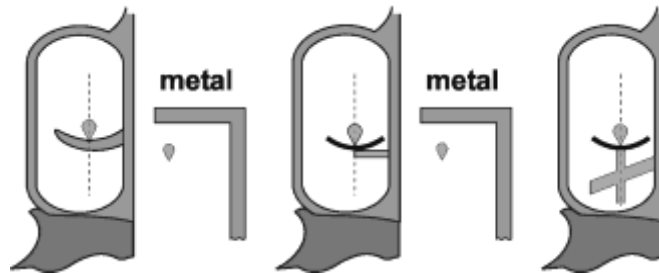

Rubber knife-edge

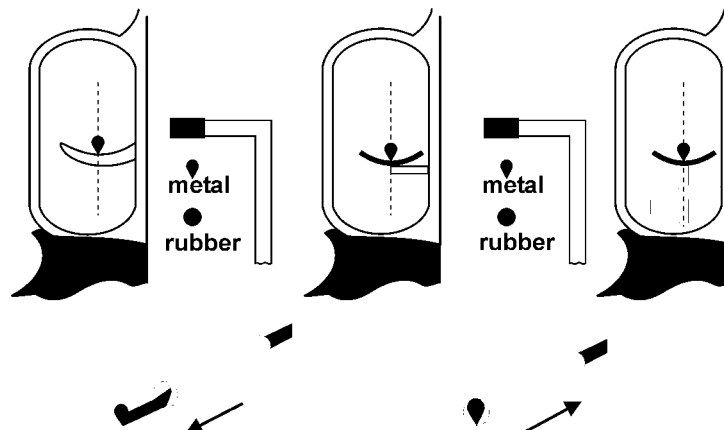
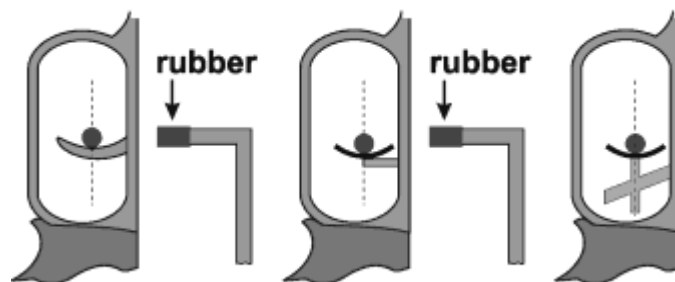

8.4.1.6.1

Note:

A weight with a metal or rubber knife-edge or a round configuration with rubber must be used. A roller on the **trigger** weight is not **permitted**. A dead weight must be used with no springs or other devices.

8.4.2

Specific Standards for 25m Pistols

The Shooter must use the same pistol in all stages and series of an event unless it ceases to function.

8.6.4.4.3.1 During each series the target is shown five (5) times or, when electronic scoring targets are used, the green lights come on each time for three (3) seconds (+ 0.2 seconds – 0.0 second). The time between each appearance (the edge-on position) or, when Electronic Scoring Targets are used, the red lights are on must be seven (7) seconds (\pm 0.1 second). One (1) shot only will be fired during each “appearance” of the target.

8.6.6.1.1.3 If a shooter **fires more sighting shots** than are provided for in the program, or are approved by the Range Officer or Jury, he must be penalized by the deduction of two (2) points from the first series of his competition score for each excessive sighting shot fired. **This penalty is in addition to the penalty of two (2) points that may be imposed when a shooter loads more than five (5) cartridges.**

8.6.6.4 **Cross-fires on sighting targets**

8.6.8.1 If it is found that his **claim is justified**, he may begin **the series** again.

8.7 MALFUNCTIONS

Only one (1) malfunction (either allowable or non allowable) is permitted except when stipulated in a specific event.

8.7.4.3.1.4 the cartridge case has not been extracted or ejected; **this applies even if a case catcher is used;**

8.7.4.5.2.2.2 shot(s) to complete the series must be fired in the immediately following series (in the Precision Stage a time of one (1) minute will be allowed for each shot to be fired) or **starting on the first exposure** (Rapid Fire Stage).

8.7.5.2.4.1 If there is a failure of a single target or a group of five targets (25m Rapid Fire Pistol Event) the shooter **will** be moved to another firing position in the same, or if necessary, a following relay. After the problem is resolved, a separate sighting series and a one (1) minute pause will be given before the firing of the next series in accordance with the rule above.

8.11 INDEX

Barrels – See the Pistol Specification Table	8.4.1.2
Deduction of points – Disturbances – claim not justified	8.6.7.2
Pistol Events – See the Pistol Event Table	8.8
Ready Position 25m events – drawing	8.6.1.3

Shotgun Rules

9.4.2.7 Ported Barrels and Ported Interchangeable Chokes

- Ported barrels are permitted, provided they do not extend back further than **20 cm** as measured from the end of the muzzle.
- Ported interchangeable chokes are permitted, provided their porting plus any barrel porting does not exceed **20 cm** as measured from the muzzle end of the interchangeable fitted choke.

Renumber 9.5.4.1.1 to 9.5.4.1

Renumber 9.5.4.1.2 to 9.5.4.1.1

9.5.6.1 The Referee must be assisted by two (2) or three (3) Assistant Referees:

- these are usually appointed in rotation from among the shooters who have fired in the previous squad
- all shooters must serve in this function when designated.
- the Organizing Committee may provide substitute qualified Assistant Referees
- the Referee may accept experienced substitutes
- a coach must not be a substitute if there is a shooter of the same nation in the squad

9.6.2.1 Pre-Event Training

- must be provided for each event the day before the commencement of the official competition on the same ranges and same make and colour of targets as are to be used in the official competition
- all such training must be scheduled fairly between those shooters present in order that no advantage is given

S.9.6.14.14.3 Additional “NO BIRD” Rules applying to doubles

Both targets must be declared “NO BIRD” and a repeat double thrown, to determine the result of both shots when:

- either target is irregular (see note)
- a single target is thrown in “Doubles”
- the first shot breaks both targets (a shooter is permitted only two (2) attempts on any one station , if the same situation occurs for the third time the first target must be declared a “HIT” and the second “LOST”)
- fragments from the first target break the second target
- the targets collide
- the shooter suffers an allowable malfunction of gun or cartridge and is unable to fire the first shot
- both shots are fired simultaneously

9.11 CLASSIFICATION AND SCORING PROCEDURES

The jury member responsible for the shotgun classification will either be appointed by the ISSF or by the Technical Delegate in conjunction with the Chairman of the Shotgun Jury from amongst the appointed Jury Members.

9.11.2 SCORING PROCEDURE

Scoring is done officially on each range for each round of 25 targets in Trap and Skeet, 25 doubles for Men or 20 doubles for Women in the Double Trap events:

- in all ISSF supervised competitions the individual scores must be kept on each range by two (2) separate persons, these are usually Assistant Referees.
- one person must maintain a permanent official scorecard
- the second person must maintain a **manual scoreboard**, except that where an **electronic scoreboard** is used, it must be maintained by the Referee

9.11.3 SCOREBOARDS

9.11.3.1 Ranges with **Electronic Scoreboards**.

The Referee must control the operation of the electronic **Scoreboard**.

9.11.3.3 **Electronic Scoreboard Errors**

If at any stage the electronic **scoreboard** should display an incorrect score, the Referee must stop the shooting and with minimum delay take whatever action is required to correct it.

9.11.3.3.1 If for any reason, it is not possible to correct the display, the following action will be taken:

- the official scoreboard must be examined and verified up to the point where the **electronic scoreboard** failed
- then, if possible to substitute quickly a **manual scoreboard**, enter the scores upon it up to the point of failure and continue the round
- if it is not possible to substitute **a manual scoreboard**, an additional scorecard must be introduced, the verified scores entered upon it and the round must then continue with the second scorecard under the control of a qualified person appointed by the Chief of Referees
- in the event that there is a difference in the recorded scores between the two (2) scorecards, that which is under the control of the official appointed by the Chief of Referees, must prevail.

9.11.3.4 Ranges with **Manual Scoreboards**

Three (3) persons must be appointed as Assistant Referees, as follows:

- the first person must be positioned at the rear of the firing line to maintain a permanent official scorecard
- the second person must act as an Assistant Referee and also maintain **the manual** scoreboard
- the third person must act as an Assistant Referee on the side opposite the **manual** scoreboard and also to check that the scores shown on it are registered correctly.
- each scorer must mark the card or board independently but based only on the decision given by the Referee
- at the conclusion of each round the results must be compared and the correct scores entered upon the official scorecard before it is delivered to the Classification Office
- the scores shown on the manual **score**board must prevail if there are unresolved differences.

9.12.3.4 Ties for 7th Place and Below

Individual tied scores ranking 7th place and below, not decided by a shoot-off must be ranked **according** to the "**Count Back**" rule.

Renumber 9.13.2.1.1 to 9.13.2.1

9.13.4.4.2 The shooter will then be permitted to shoot the missed round at a time and on the range decided by the Chief of Referees with a deduction of three (3) targets from the make up round. **The shooter should if possible shoot a make up round on the same range as the one he had to leave.**

Replace chapter 9.14 "Finals" by the following:

9.14 FINALS

9.14.1 SHOTGUN EVENTS

Event	Men (Qualification + Finals)	Women (Qualifications + Finals)
Trap	125 (5x25) + Finals (25)	75 (3x25)+ Finals (25)
Double Trap	150 (3x50) + Finals (50)	-
Skeet	125 (5x25) + Finals (25)	75 (3x25)+ Finals (25)

The technical rules for each event also apply to the Finals for these events except where differences are shown here.

9.14.2 NUMBER OF FINALISTS IN EACH EVENT

The six (6) highest-ranking competitors in the Qualification of each event advance to the Finals.

9.14.3 ORDER OF SHOOTING IN THE FINALS

- each Finalist will shoot in the order as decided by their qualification score. The shooter with the highest qualification score will shoot at position No.6, the next highest qualification score at No.5 and so on (6-5-4-3-2-1).
- shooters entering the Finals with tied scores will have their shooting order determined according to the "Count Back" rule. If they are still tied the shooting order will be determined by drawing of lots.
- the shooting order of shooters with perfect scores must be decided by the Jury by drawing lots.

9.14.4 RANGE COMMANDS

All range commands will be given in the English language.

Procedure for Finals in Shotgun events

Time before Start Time	Stage	Procedure
20:00 minutes before	Finalists Report and Warm-up	<p>Team Leaders are responsible for ensuring that their shooters are presented to the Jury in the designated preparation area. The Finalists must report to the Finals range preparation area at least 20 minutes before the Finals round start time. The Finalists must report with their shotguns, competition clothing and a national team uniform that may be worn in the award ceremony. The Jury must complete any necessary checks during the reporting period.</p> <p>The Referee will authorize the Finalists to go to the shooting stations to do warm-up exercises or dry fire. The Referee must use the Final Round Start List to confirm that all competitors are present and that their names and nations are correctly recorded in the results system and on the scoreboards.</p>
12:00 minutes before	Target Showing and Test Fire	<p>The Referee will authorize the Finalists to complete their test fire shots and show the targets according to the rules for each event.</p>
5:00 minutes before	Finalists Assemble	<p>The six (6) Finalists, the Referee and the Jury Member in charge must report to a designated presentation area in the center of the range near the spectator stand. Late or ABSENT procedures start (Rule 9.14.6).</p>

4:00 minutes before	Introduction of Finalists	The Announcer will introduce the Finalists by giving the name, qualification result and brief information about each Finalist's most important accomplishments. Finalists will be introduced in order starting with the Finalist on the right. The Announcer will also introduce the Referee and the Jury Member in charge.
1:00 minute before	Finals Preparation	One (1) minute before the first Finals round shot, the Referee will instruct the Finalists to go to their shooting stations.
0:00 minute before	Finals Starts	<p>The Referee will instruct the first Finalist (6th ranking Finalist) to begin by giving the command "READY". The first competitor in Trap or Double Trap then has ten (10) seconds to call for the first target or double. All other Finalists in the squad have ten (10) seconds to call for the target or double after the previous shooter has fired.</p> <p>In Skeet, on every station, each Finalist has 15 seconds after the previous shooter has left the station, or the Referee has called "READY", to call for the first target(s) to be shot on that station. Any further targets to be shot on the same station by the same shooter must be called for within ten (10) seconds of the previous shot(s).</p>
After all six (6) Trap/Double Trap Finalists have fired at the same number of targets or after all the Skeet Finalists have completed a station		<p>The Referee will instruct the Finalists to pause. Television will use this pause to display current scores and rankings in their productions. After 20 seconds, the Referee will instruct the first Finalist (6th ranking competitor) to start by giving the command "READY".</p> <p>The first Finalist in Trap or Double Trap will then have ten (10) seconds to call for the next target or double. All other Finalists in the squad will have ten (10) seconds to call for their target or double after the previous shooter has fired.</p> <p>The first Finalist in Skeet after receiving the Referee's command "READY" on each station will then have 15 seconds to call for the first target(s) to be shot on that station. Any further targets to be shot on the same station by the same shooter must be called for within ten (10) seconds of the previous shot(s).</p>

<p>After all Finals round shots are complete</p>	<p>The Referee immediately determines whether there are any ties or protests. If there are no ties or protests, the Referee must immediately declare “THERE ARE NO TIES. RESULTS ARE FINAL”.</p> <p>If there are ties for first, second or third place only, the Jury Member in charge must conduct the draw for firing order without further delay. The Referee will then conduct the tie-breaking Shoot-off(s) until ties are broken according to Rule 9.12.1.2 (lower ranking first). Ties below third place will be broken by the higher Finals round score (if Finals scores are equal, apply the count-back rule to the final round scores), or if the tie is not broken, by the qualification rank.</p> <p>The Referee must immediately declare “RESULTS ARE FINAL”.</p>
<p>After Finals round results are complete</p>	<p>After the Referee declares “RESULTS ARE FINAL”, the Announcer must immediately announce:</p> <p>“THE GOLD MEDAL WINNER IS (NAME) FROM (NATION) WITH A TOTAL SCORE OF (SCORE)”</p> <p>“THE SILVER MEDAL WINNER IS (NAME) FROM (NATION) WITH A TOTAL SCORE OF (SCORE)”</p> <p>“THE BRONZE MEDAL WINNER IS (NAME) FROM (NATION) WITH A TOTAL SCORE OF (SCORE)”</p>

9.14.5 **STARTING TIME**

As printed in the official shooting program unless amended:

- any alteration to this published time must be given to the team leaders concerned and the media as soon as possible.
- a separate notice must be displayed on the Finals range and the official information board.
- a public announcement must be made giving notice of the amended times.

9.14.6 **LATE OR “ABSENT” SHOOTER**

Any Finalist who is not on his assigned position before the Presentation of the Finalists begins, after calling the name three (3) times within one (1) minute, is automatically given the last place(s) in the Finals with his Qualification Score(s) and is not allowed to participate in the Finals.

9.14.7 **“FINALS ROUND” COMPETITION PROCEDURES**

9.14.7.1 Except where otherwise shown in this section, the normal rules for Trap, Double Trap and Skeet will be applied for the appropriate Finals.

9.14.7.2 Trap

- Before the start of the presentation of the Finalists, the shooters must be shown a target from each trap machine. After that each shooter is permitted to test fire one (1) shot.
- Each shooter is permitted only one (1) shot at each target.
- If a shooter loads two (2) cartridges and fires a second shot, the target must be declared “**LOST**” whether or not it was “**HIT**” by either of the shots.

9.14.7.3 Double Trap

- Before the start of the presentation of the Finalists each shooter must be permitted to test fire two (2) shots. After that the squad must be shown a regular double. After the presentation of Finalists, the squad will be shown another regular double before shooting commences.

9.14.7.4 Skeet

- Before the start of the presentation of the Finalists each shooter must be permitted to test fire two (2) shots.
- After that, the shooters assembled on Station 1 must be shown a regular target from each traphouse.

9.14.8 MALFUNCTIONS of SHOTGUN or AMMUNITION

9.14.8.1 If the Referee decides that a disabled shotgun, or malfunctioning of the shotgun or ammunition, is not the fault of the shooter, the shooter must be given **three (3) minutes** time in which to repair the shotgun or obtain another approved shotgun, or replace his ammunition. If this cannot be done **within three (3) minutes**, the shooter must withdraw. After the malfunction is corrected or the shooter withdraws, the Finals must continue. A withdrawn shooter’s final ranking will be determined by the total number of targets hit when the malfunction occurred.

9.14.8.2 Number of malfunctions

- the shooter is allowed a maximum of two (2) malfunctions during the Finals, including any shoot-off after the Finals, whether or not he has tried to correct the malfunction
- any regular targets on which any further malfunction of shotgun or ammunition occurs will be declared “**LOST**” whether or not the shooter attempted to fire or not.

9.14.9 PROTESTS DURING FINALS

Any protest received will be decided immediately by the Jury. The decision is final.

9.14.10 FINALS RANGE EQUIPMENT FAILURE

9.14.10.1 Procedure

If a malfunction of Finals Range equipment occurs, the completed shots at the stage of the breakdown will be scored as a sub-total and the following course of action applied:

- if the equipment can be repaired **within 30 minutes** the remaining shots will be completed
- if it is decided that repairs cannot be completed within that time and it is possible to move to another range with the same setting within that time, the Finals will be completed on this new range
- no protest against an uneven distribution of targets in Trap will be considered

9.14.10.2 Termination of Uncompleted Finals

If the Finals cannot be continued on any suitable range **by the end of 30 minutes** after the breakdown the Jury must declare the Finals terminated.

9.14.10.3 Ranking procedure after an uncompleted Finals

The following ranking procedure will then apply:

- the record of the shots taken in the Finals up to the point of breakdown must be examined
- at a point where all the shooters have shot at the same number of targets a "sub-score" will be recorded
- this "sub-score" plus the score of the qualification rounds will be the total for the event
- shooters with tied scores must have their ranking determined by the "count back rule"

awards will then be made on this basis.

9.16 INDEX

Absent Shooter – DEDUCTION of three (3) Targets	9.13.4.3
Ammunition – Cartridge specifications	9.4.3.1
Assistant Referee – absent – DEDUCTION of one (1) target	9.5.6.3
Assistant Referees – duties	9.5.6.2
Carrying guns – Safety	9.2.2
Chief of Referees – duties	9.5.4.2
Chief Range Officer – duties	9.5.3.3
Double Trap – Conduct of a Round of Double Trap	D.9.6.9.1
Double Trap – “No Bird” - Double	D.9.6.12
Double Trap – Refused Doubles	D.9.6.11
Double Trap – Trap Setting Table	D.9.6.10.1
Electronic Scoreboards	9.11.3.1
Electronic Scoreboards Errors	9.11.3.3
Equipment Control – Program of Inspection	9.4.1
Finals – Disabled Shotgun or misfires	9.14.9.1

Finals – Ranking Procedure after an Uncompleted Final	9.14.11.3
Guns – types permitted	9.4.2.1
Lost Target(s)	9.10.5
Manual Scoreboards	9.11.3.4
Scoreboards – Ensure the Scores on the Scoreboard	9.11.3.2
Skeet Ranges – drawing	6.3.22.8
Squadding –general	9.7.4
Visible Scoreboards	9.11.3

9.15.3 Trap Setting Tables (I-IX) (add missing table V and VI)

Table V					
Group	Number of Traps	Direction of trajectory from the Traps	Elevation trajectory at 10m level ground	Length of trajectory for all traps	NOTE
1	1	45 degrees to right	1.60 m	76 m +/-1 m	
	2	0 degrees	3.00 m		
	3	45 degrees to left	2.00 m		
2	4	40 degrees to right	2.80 m		
	5	10 degrees to left	1.50 m		
	6	45 degrees to left	2.00 m		
3	7	35 degrees to right	3.00 m		
	8	5 degrees to left	1.80 m		
	9	40 degrees to left	1.50 m		
4	10	25 degrees to right	1.80 m		
	11	0 degrees	1.60 m		
	12	30 degrees to left	3.40 m		
5	13	30 degrees to right	2.00 m		
	14	10 degrees to right	2.40 m		
	15	15 degrees to left	1.80 m		
Table VI					
Group	Number of Traps	Direction of trajectory from the Traps	Elevation trajectory at 10m level ground	Length of trajectory for all traps	NOTE
1	1	40 degrees to right	2.00 m	76 m +/-1 m	
	2	0 degrees	3.30 m		
	3	35 degrees to left	1.50 m		
2	4	35 degrees to right	2.50 m		
	5	10 degrees to right	1.50 m		
	6	35 degrees to left	2.00 m		
3	7	35 degrees to right	2.00 m		
	8	5 degrees to left	1.50 m		
	9	40 degrees to left	3.30 m		
4	10	45 degrees to right	1.50 m		
	11	10 degrees to left	3.00 m		
	12	25 degrees to left	2.60 m		
5	13	25 degrees to right	2.40 m		
	14	5 degrees to right	1.50 m		
	15	45 degrees to left	2.00 m		

Running Target Rules

10.4.1.3.2 10m Rifles

Any type of sights are permitted except that optical sights are limited to a non-variable of maximum four power (4 x) magnification (tolerance = +0.4 x). Examination of magnification power will be done by mechanical or optical devices authorized by ISSF.

10.10 RUNNING TARGET SPECIFICATION TABLE

Sights
Any sights, telescope with non variable maximum four power (tolerance + 0.4 x) magnification.

Replace old drawing with drawing below

10.11

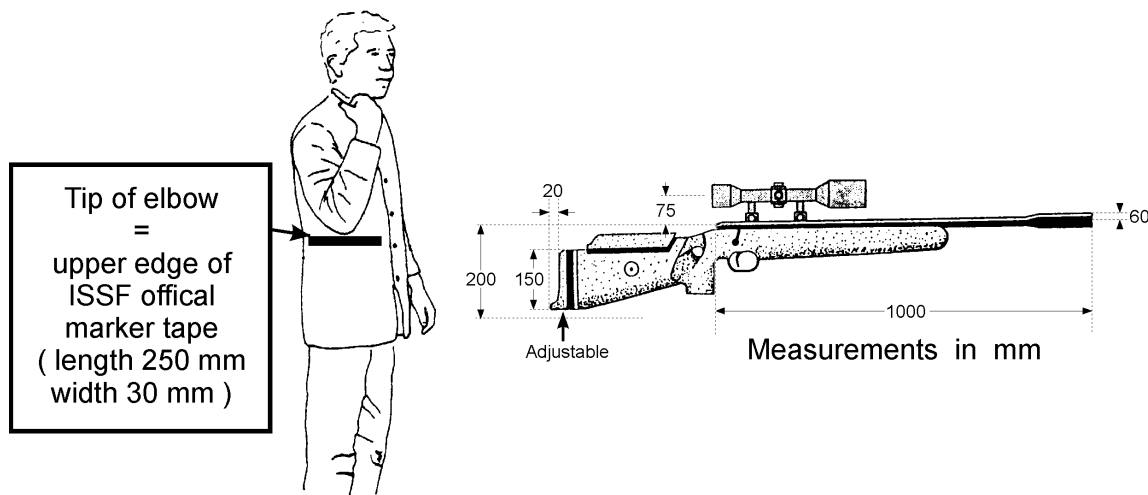

10.12.14 The scoring will be done in decimals. The shooter with the higher score of the pair (1 and 4, 2 and 3) will receive the point. If there is a tie between a pair, no shooter gets a point. The shooter who receives six points is the winner of this match.

10.13 INDEX

General Standards for 50m and 10m Rifles - Table	10.10
Exchange of the rifle sight	10.4.1.4

110421 Errata E2009/21.04.2011 10:42:00